

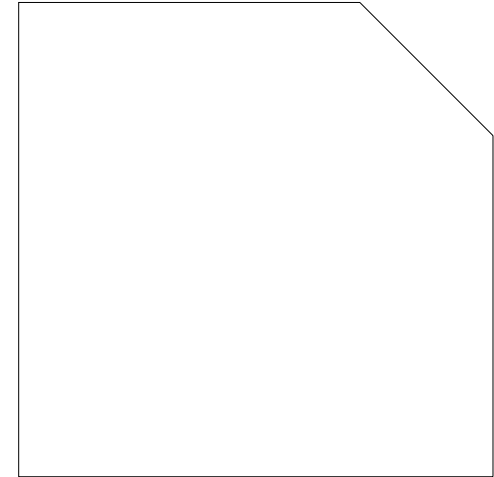

DIFFICULTY RATING:		CUSTOMER SIGNATURE INDICATES APPROVAL OF SHAPE AS SHOWN AND AGREEMENT TO PURCHASE ALL SHAPES ORDERED AND EQUIPMENT AS INDICATED ON PURCHASE ORDER.
STRETCHER:		
PRODUCT CODE:		SURFACES NOT DESIGNATED AS FACES MAY OR MAY NOT BE SOLID AT MANUFACTURERS OPTION IN ORDER TO REDUCE COST.
YARD SERVICES CHARGE:		
SHAPER CAP CHARGE:		
SPECIAL EQUIP:		
CUST APPRV:		
PLANT APPRV:		

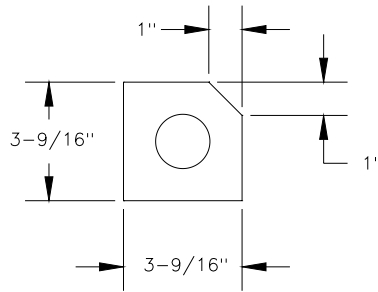
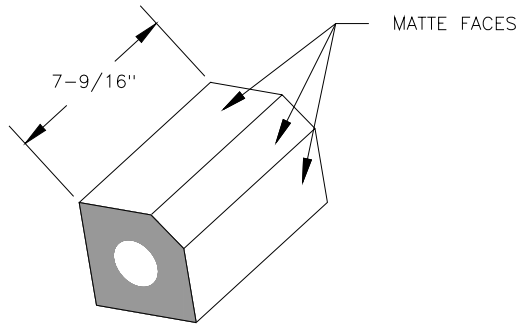

 INTERSTATE BRICK ENGINEERING DEPARTMENT WEST JORDAN, UTAH		<i>"Nothing Else Stacks Up"</i>
CUST:		DRN BY: J. ECK
JOB:		DATE: 4/30/02
UNIT:	7-9/16" MOD STRETCHER	
COLOR:		
SIZE:	3-1/2" MODULAR	
QTY:		MD3916_1inchamferedsill

Demo Version